

# Design Span®hp

Featuring

**Zincalume® For Twice the Life!**

Zincalume combines the strength of steel with the corrosion resistance of aluminum for twice the life of most zinc coatings.

**Design Span®hp** is a performance-rated structural standing seam metal roof system with net coverage of 12", 17" up to 24". Design Span®hp is excellent as a roof over metal or wood decking, and as a fascia or mansard over plywood or supports.

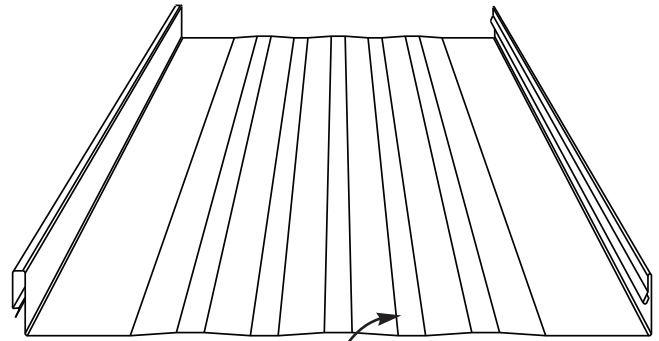

Available with subtle striations for a clean pan (17", 18", and 24" widths)

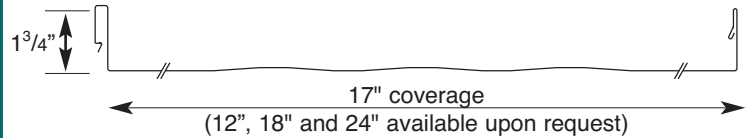

## features | benefits

- Subtle striations between ribs on 17" and wider panels reduce the appearance of oil-canning.
- Available in a wide variety of standard colors in the DuraTech™5000 (polyvinylidene flouride) coating system, and the ZACtique®II treatment.
- Tested in accordance with UL580 & ASTM E1592.
- Meets UL 90 wind uplift requirement for 12", 17" and 18" wide panels.
- Has been tested for air infiltration per ASTM E1680, and water infiltration per ASTM E1646.
- Can be installed over solid substrates or spaced support members at spans to 4'-0".
- Available with a 1 1/8" notch at both ends of each panel for the ease of turning under; reducing installation labor and costs (see back for illustration).
- Factory applied butyl sealant is standard.
- Snap-together panel, no field seaming required.

Design Span®hp Section Properties					
Design Span® hp-12"					
Gauge	Wt. (lbs./ft.²)	S+ (in.³/ft.)	I+ (in.⁴/ft.)	S- (in.³/ft.)	I- (in.⁴/ft.)
24	1.39	0.0822	0.1178	0.0648	0.0595
22	1.78	0.1046	0.1502	0.0932	0.0834
Design Span® hp-17" and 18"					
Gauge	Wt. (lbs./ft.²)	S+ (in.³/ft.)	I+ (in.⁴/ft.)	S- (in.³/ft.)	I- (in.⁴/ft.)
24	1.24	0.0566	0.0859	0.0434	0.0399
22	1.58	0.0721	0.1096	0.0625	0.0559
Design Span® hp-24"					
Gauge	Wt. (lbs./ft.²)	S+ (in.³/ft.)	I+ (in.⁴/ft.)	S- (in.³/ft.)	I- (in.⁴/ft.)
24	1.17	0.045	0.0678	0.0326	0.03
22	1.49	0.0552	0.0866	0.047	0.0421



[www.aepspan.com](http://www.aepspan.com)

Tacoma, WA 800-733-4933, 253-383-4955 FAX 253-272-0791  
 Dallas, TX 800-527-2503, 214-827-1740 FAX 214-828-1394  
 Kernersville, NC 800-527-2503, 214-827-1740 FAX 214-828-1394

# Design Span<sup>®</sup> hp

## Design Span hp 12" Load/Span Table

			Allowable Uniform Distributed Load (psf)				
			Span				
			2'	2'6"	3'	3'6"	4'
24 Gauge	SS	f	328	210	146	107	82
		L/240	328	210	146	107	82
	DS	f	259	165	115	84	64
		L/240	259	165	115	84	64
	TS	f	324	207	144	105	81
		L/240	324	207	144	105	81
22 Gauge	SS	f	418	267	185	136	104
		L/240	418	267	185	136	104
	DS	f	372	238	165	121	93
		L/240	372	238	165	121	93
	TS	f	466	298	207	152	116
		L/240	466	298	207	152	116

## Design Span hp 17" and 18" Load/Span Table

			Allowable Uniform Distributed Load (psf)				
			Span				
			2'	2'6"	3'	3'6"	4'
24 Gauge	SS	f	226	144	100	73	56
		L/240	226	144	100	73	56
	DS	f	173	111	77	56	43
		L/240	173	111	77	56	43
	TS	f	217	138	96	70	54
		L/240	217	138	96	70	54
22 Gauge	SS	f	288	184	128	94	72
		L/240	288	184	128	94	72
	DS	f	250	160	111	81	62
		L/240	250	160	111	81	62
	TS	f	312	200	138	102	78
		L/240	312	200	138	102	78

## Design Span hp 24" Load/Span Table

			Allowable Uniform Distributed Load (psf)				
			Span				
			2'	2'6"	3'	3'6"	4'
24 Gauge	SS	f	180	115	80	58	45
		L/240	180	115	80	58	45
	DS	f	130	83	57	42	32
		L/240	130	83	57	42	32
	TS	f	163	104	72	53	40
		L/240	163	104	72	53	40
22 Gauge	SS	f	220	141	98	72	55
		L/240	220	141	98	72	55
	DS	f	188	120	83	61	47
		L/240	188	120	83	61	47
	TS	f	235	150	104	76	58
		L/240	235	150	104	76	58

Can be factory notched for turning under.

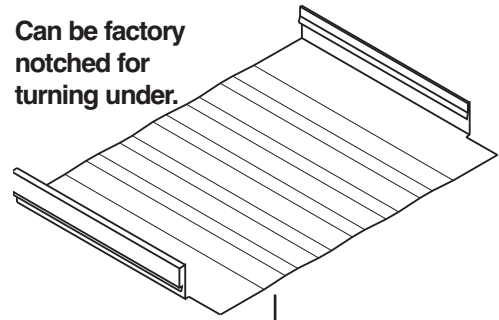

Factory notch allows panel to be field turned down.

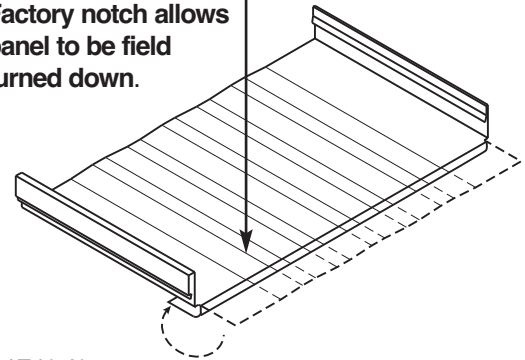

### Load Table Notes:

- Steel conforms to ASTM A-792 (Zincalume<sup>®</sup>) 40,000 psi minimum yield.
- Loads above are for "positive" loading only.
- All flat surfaces can display waviness called "oil canning". This is an inherent characteristic of flat steel products, not a defect. AEP Span makes every effort to eliminate any oil canning during the production process.

*Specifications subject to change without notice.*

### Loading Table Legend

f-Load limited by flexural bending stress

L-Span (Inches)

L/xxx-Load limited by deflection

